

Electrical Characteristics

Working Frequency	824 ~ 960MHz 1710 ~ 2170MHz
V.S.W.R	<= 2.5
Typical Antenna Gain	5 dBi
Polarization	Vertical
Impedance	50 Ohm

Material

Material of Radiator	Spring Line
Material of Plastic	Body: PVC
Material of Coaxial Cable	RG174/U

Environment

Operation Temperature	- 45°C~ + 85°C
Storage Temperature	- 45°C~ + 85°C

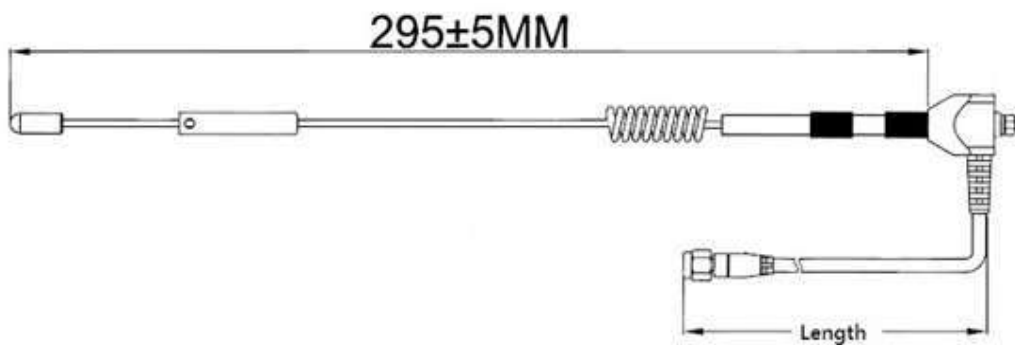

How to order

Series No.	Type	Type	Connector	Cable Type	Cable Length
SA	AS	05D	01	A	1.0
	AS: GSM/3G Screw Type	05D	01: SMA Male Optional	A: RG174... Optional	1.0:1M Optional

Electrical Characteristics

Working Frequency	824 ~ 960 MHz 1710 ~ 2170MHz
V.S.W.R	<= 2.5
Typical Antenna Gain	7 dBi
Polarization	Vertical
Impedance	50 Ohm

Material

Material of Radiator	Spring Line
Material of Plastic	Body: PVC
Material of Coaxial Cable	RG174/U

Environment

Operation Temperature	- 45°C~ + 85°C
Storage Temperature	- 45°C~ + 85°C

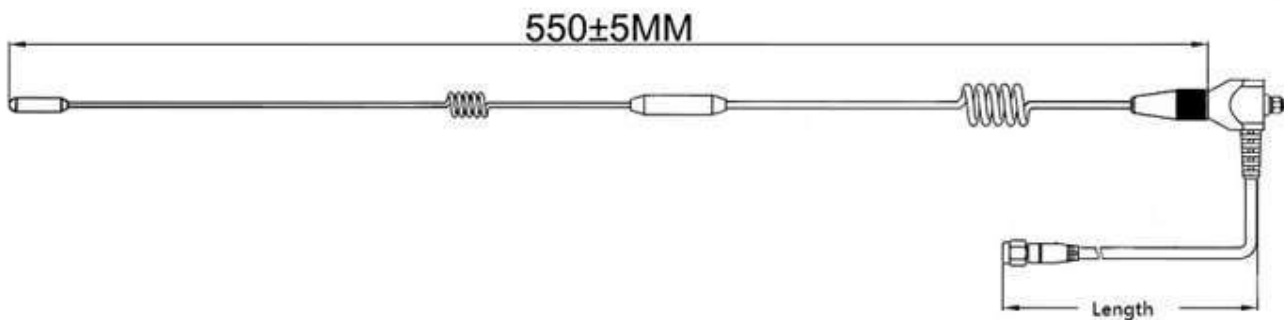
How to order

Series No.	Type	Type	Connector	Cable Type	Length
SA	AS	05E	01	A	2.5
SA	AS: GSM or 3G Screw Type	05E	01: SMA,FME... Optional	A: RG174... Optional	2.5: 2.5M Optional

Electrical Characteristics

Working Frequency	824 ~ 960 MHz 2710 ~ 2170MHz
V.S.W.R	<= 3.5
Typical Antenna Gain	2.0 dBi
Impedance	50 Ohm

Material

Material of Radiator	CU
----------------------	----

Environment

Operation Temperature	- 30°C~ + 85°C
Storage Temperature	- 30°C~ + 85°C

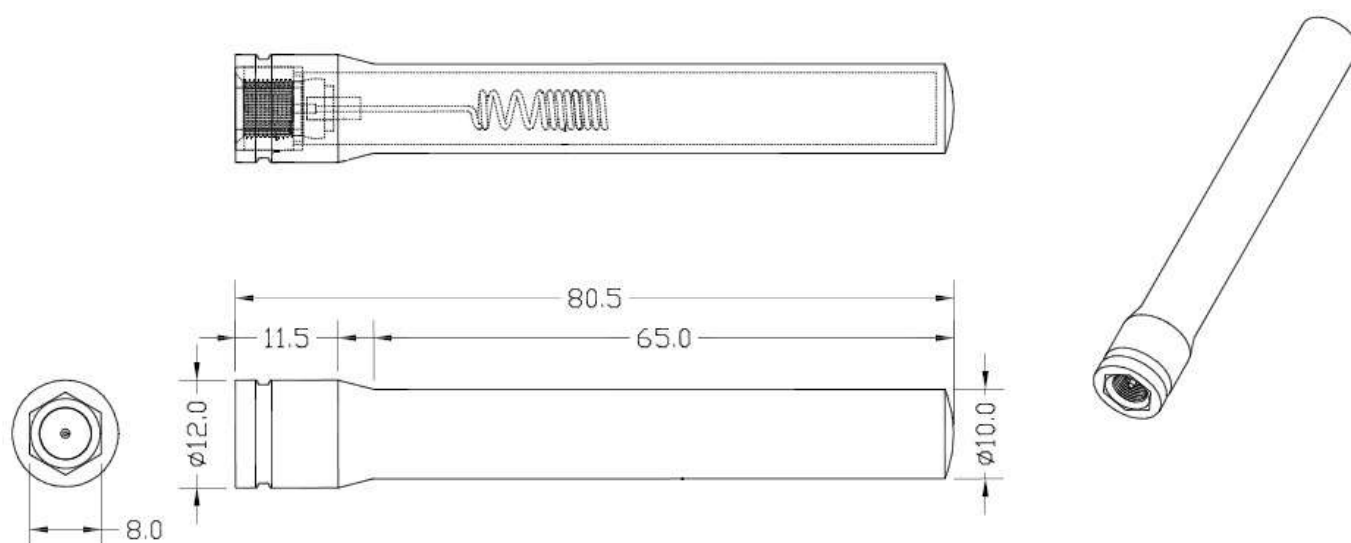
How to order

Series No.	Type	Type	Connector
SA	N 3G	05-02	01 01: SMA Straight male 04: SMA Straight male reverse

Electrical Characteristics

Working Frequency	824 ~ 960 MHz 1710 ~ 2170MHz
V.S.W.R	<= 3.5
Typical Antenna Gain	2.0 dBi
Impedance	50 Ohm

Material

Material of Radiator	CU
----------------------	----

Environment

Operation Temperature	- 30°C~ + 85°C
Storage Temperature	- 30°C~ + 85°C

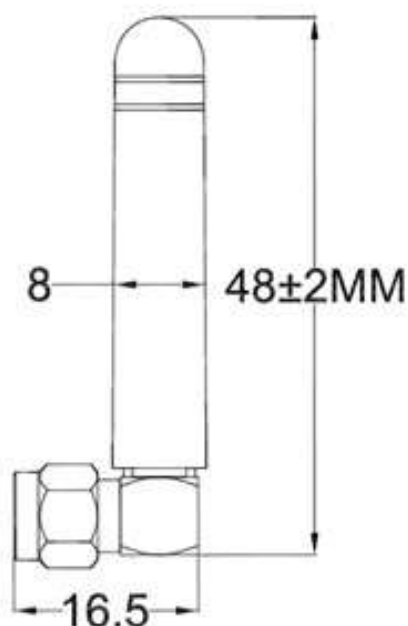
How to order

Series No.	Type	Type	Connector
SA	N	05-03	01: SMA Straight male
	3G	05-03	04: SMA Straight male reverse

Electrical Characteristics

Working Frequency	824 ~ 960 MHz 1710 ~ 2170MHz
V.S.W.R	<= 3.5
Typical Antenna Gain	2.0 dBi
Impedance	50 Ohm

Material

Material of Radiator	CU
----------------------	----

Environment

Operation Temperature	- 30°C~ + 85°C
Storage Temperature	- 30°C~ + 85°C

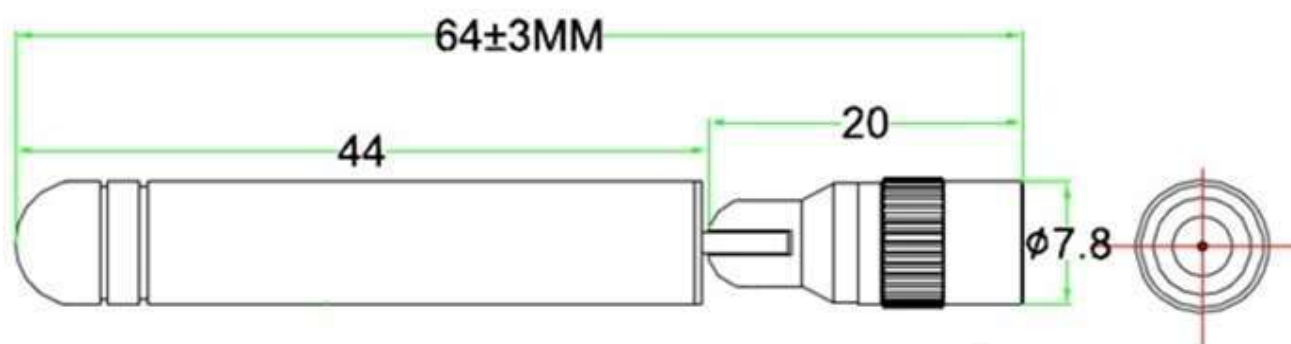
How to order

Series No.	Type	Type	Connector
SA	N	05-04	01
	3G	05-04	01: SMA Straight male 04: SMA Straight male reverse

Electrical Characteristics

Working Frequency	824 ~ 960 MHz 1710 ~ 2170MHz
V.S.W.R	<= 2.0
Typical Antenna Gain	2.0 dBi
Impedance	50 Ohm

Material

Material of Radiator	CU
----------------------	----

Environment

Operation Temperature	- 45°C~ + 85°C
Storage Temperature	- 45°C~ + 85°C

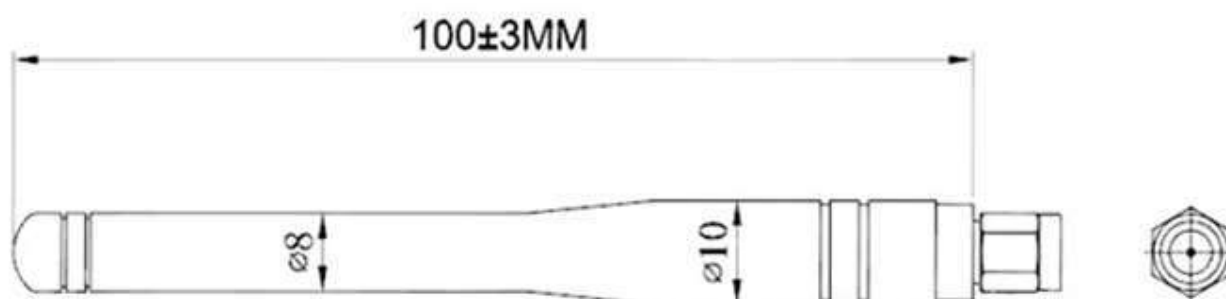
How to order

Series No.	Type	Type	Connector
SA	N	05-05	01
	3G	05-05	01: SMA Straight male 04: SMA Straight male reverse

Electrical Characteristics

Working Frequency	824 ~ 960MHz 1710 ~ 2170MHz
V.S.W.R	<= 2.0
Typical Antenna Gain	2.0 dBi
Impedance	50 Ohm

Material

Material of Radiator	CU
----------------------	----

Environment

Operation Temperature	- 45°C~ + 85°C
Storage Temperature	- 45°C~ + 85°C

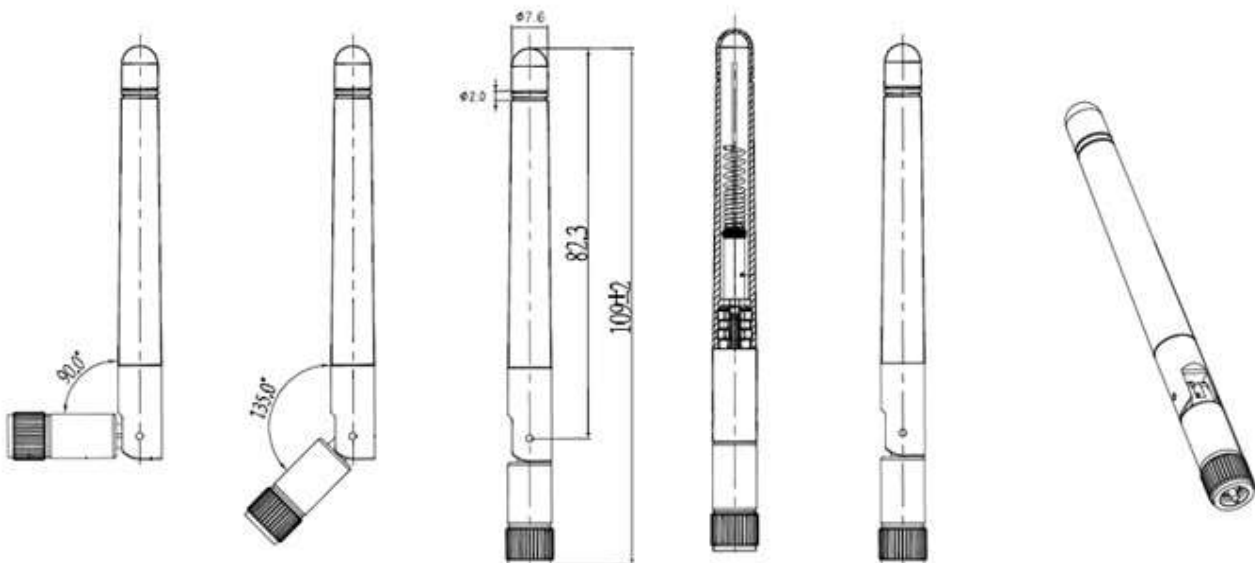
How to order

Series No.	TYPE	Type	Connector
SA	N	05-06	01
	3G	05-06	01: SMA Straight male 04: SMA Straight male reverse

Electrical Characteristics

Working Frequency	824/880/960/1880/ 1990/2170MHz
V.S.W.R	<= 2.5
Typical Antenna Gain	3 dBi
Polarization	Vertical
Impedance	50 Ohm

Material

Material of Radiator	CU
Material of Coaxial Cable	RG174/U

Environment

Operation Temperature	- 45°C~ + 85°C
Storage Temperature	- 45°C~ + 85°C

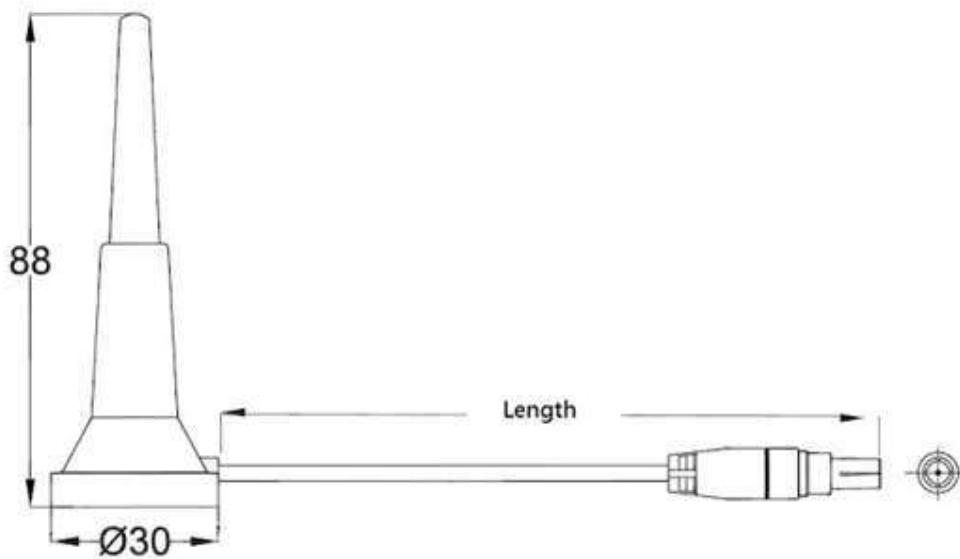
How to order

Series No.	Type	Type	Connector	Cable	Length
SA	N	05-07	14	A	1.0
	3G	05-07	14: CRC9	A: RG174	1.0: 1M Optional

Electrical Characteristics

Working Frequency	824/880/960/1880/ 1990/2170MHz
V.S.W.R	<= 3.0
Typical Antenna Gain	5 dBi
Polarization	Linear
Impedance	50 Ohm

Material

Material of Radiator	Spring Line
Material of Plastic	Body: ABS
Material of Coaxial Cable	RG174/U

Environment

Operation Temperature	- 30°C~ + 85°C
Storage Temperature	- 30°C~ + 85°C

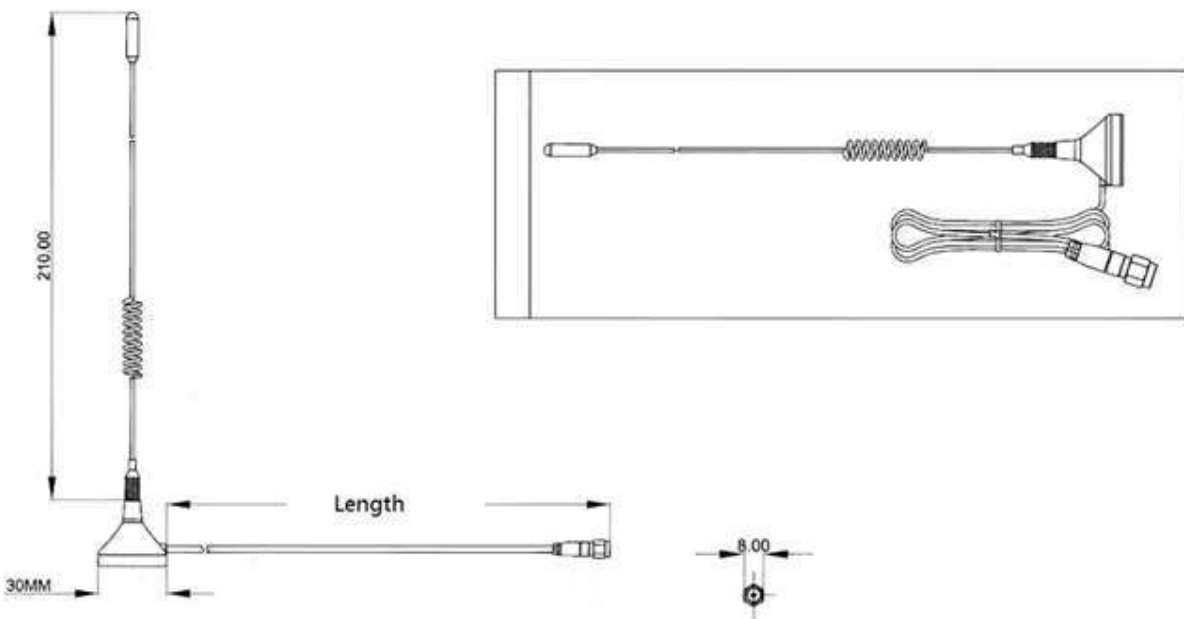
How to order

Series No.	Type	Type	Connector	Cable	Length
SA	N	05-08	01	A	2.5
	3G	05-08	01: SMA Straight male 04: SMA Straight male reverse	A: RG174	2.5M Optional

Electrical Characteristics

Working Frequency	824/880/960/1880/ 1990/2170MHz
V.S.W.R	< = 2.0
Typical Antenna Gain	3.0 dBi
Polarization	Linear
Impedance	50 Ohm

Material

Material of Radiator	CU
Material of Plastic	Body: ABS
Antenna Material	PCB

Environment

Operation Temperature	- 45°C~ + 85°C
Storage Temperature	- 45°C~ + 85°C

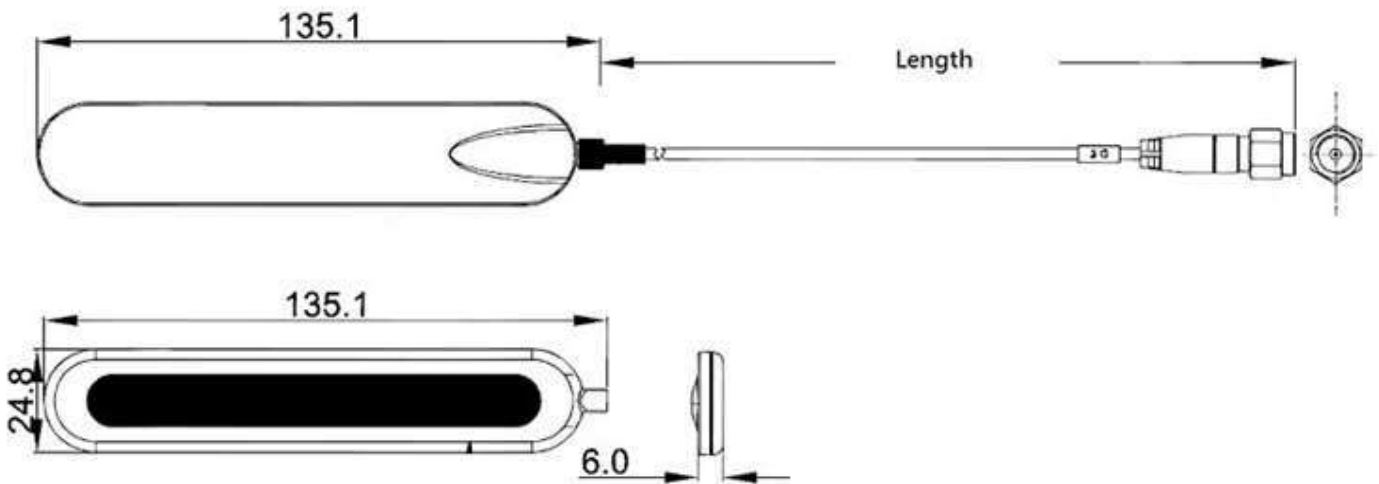
How to order

Series No.	Type	Type	Connector	Cable	Length
SA	N	05-09	01	B	0.3
	3G	05-09	01: SMA Straight male 04: SMA Straight male revers	B: RG316	0.3M Optional

Electrical Characteristics

Working Frequency	824 ~ 960MHz 1710 ~ 2170MHz
V.S.W.R	< = 3.0
Typical Antenna Gain	3.0 dBi
Polarization	Linear
Impedance	50 Ohm

Material

Material of Radiator	CU
Material of Plastic	Body: ABS
Material of Coaxial Cable	RG174/U

Environment

Operation Temperature	- 45°C~ + 85°C
Storage Temperature	- 45°C~ + 85°C

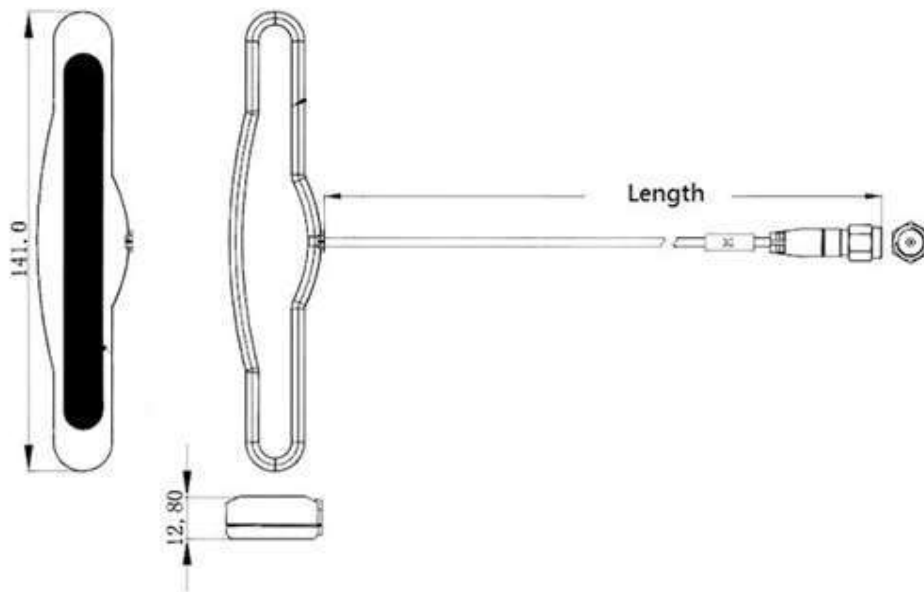
How to order

Series No.	Type	Type	Connector	Cable	Length
SA	N	05-10	01	A	2.0
	3G	05-10	01: SMA Straight male 04: SMA Straight male reverse	A: RG174	2.0M Optional

Electrical Characteristics

Working Frequency	824 ~ 960MHz 1710 ~ 2170MHz
V.S.W.R	<= 3.5
Typical Antenna Gain	3 dBi
Polarization	Linear
Impedance	50 Ohm

Material

Material of Radiator	CU
Material of Plastic	PC + ABS

Environment

Operation Temperature	- 45°C~ + 85°C
Storage Temperature	- 45°C~ + 85°C

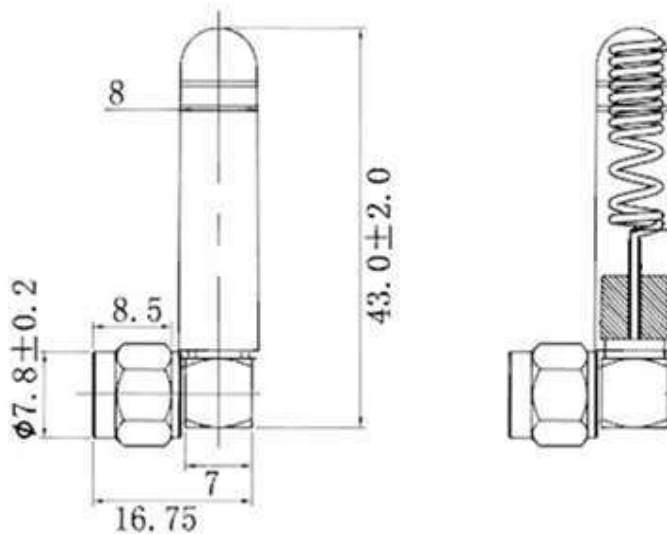
How to order

Series No.	Type	Type	Connector
SA	N	05-11	01
	3G	05-11	01: SMA Straight male 04: SMA Straight male reverse

Electrical Characteristics

Working Frequency	824/880/960/1880/1990/2170MHz
V.S.W.R	<= 3.0
Typical Antenna Gain	2.0 dBi
Polarization	Linear
Impedance	50 Ohm

Material

Material of Radiator	Spring Line
Material of Plastic	PC + ABS
Material of Coaxial Cable	

Environment

Operation Temperature	- 30°C~ + 85°C
Storage Temperature	- 30°C~ + 85°C

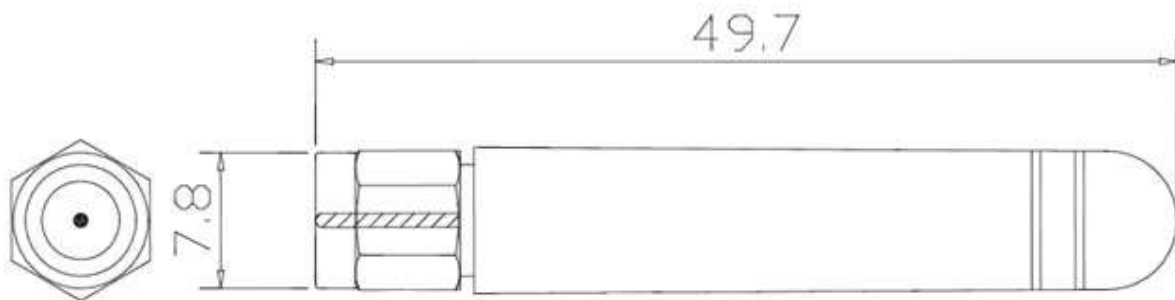
How to order

Series No.	Type	Type	Connector
SA	N	05-12	01
	3G	05-12	01: SMA Straight male 04: SMA Straight male reverse